

Strapack[®]

Automatic Side-Seal Model



RQ-8Y

RQ-8Y

Side-Seal Model



■ FAST!

1.7 seconds per strap (equivalent to 35 straps per minute).

■ ADAPTS EASILY TO AUTOMATED PACKAGING LINES

The machine fits any existing or proposed conveyor system without modification, adapts to any conveyor height and requires no special equipment.

■ WIDE ADAPTABILITY TO FULLY-AUTOMATED PACKAGING LINES

End-of-cycle and strapping error signals are available as options. Larger arch sizes offer a wide range of applications, particularly for large and heavy packages.

■ EASY STRAP LOADING

No complicated strap threading. It only requires a touch of the outside lever.

■ VARIABLE TENSION

A single dial provides a wide range of tension for all packages. Tension adjustable up to 80kg (175lbs.), equivalent to 150mm (6 inch) stroke.

■ QUICK HEATER

In less than 25 seconds, operating temperature is reached.

■ EMPTY STRAP COIL DETECTION

Operation automatically stops when the strap coil is empty plus an optional warning signal is available. Easy removal of any excess strap ensures uninterrupted operation.

■ RE-FEED FUNCTION

Features automatic resetting of the machine for continuous operation even if a strap forwarding failure were to occur.

■ AUTOMATIC STRAP EJECTION

If a strap cycle is accidentally started without a package, empty strap loops are automatically ejected and all functions are reset for the next cycle.

■ SELF-DIAGNOSTIC MECHANISM

A programmable microprocessor constantly monitors critical functions—any irregularity detected is immediately displayed.

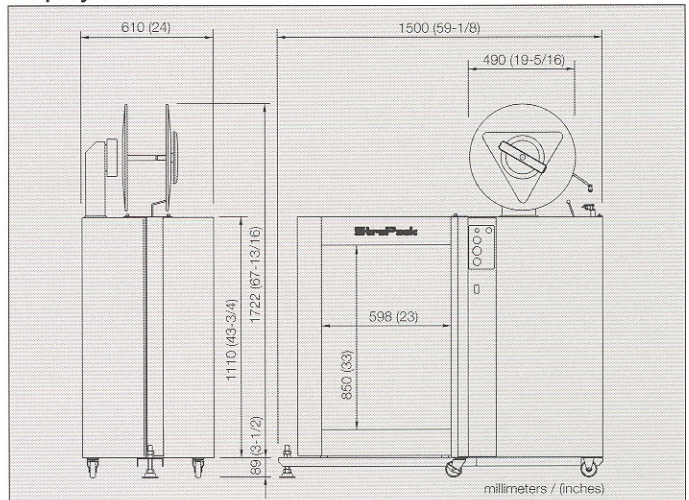

■ Standard Specifications

Dimensions	Width	1500mm	59-1/8 in.
	Height	1722mm	67-13/16 in.
	Depth	610mm	24 in.
	Weight	200kg	440 lbs.
Arch Size	W 600 × H 850mm		W 23 × H 33 in.
Package Size	Max	W 570 × H 820mm	W 22-1/2 × H 32-5/16 in.
	Min	W 30 × H 100mm	W 1-1/4 × H 4 in.
Joint / Strap / Coil	heat seal / polypropylene / ID 200 × OD 450 × W 200mm		heat seal / polypropylene / ID 8 × OD 18 × W 8 in.
Strap Width	5, 6, 9, 12, 15.5mm		1/4, 3/8, 1/2, 5/8 in.
Strap Tension	Max. 80kg 150mm stroke	Max. 176 lbs. 6 in. stroke	
Speed	1.7 sec./strap 35 straps per min.		
Power Supply	110, 120, 200, 220, 230, 240V 1 phase 50 / 60Hz 0.65KVA		

Dimensions and specifications are subject to change without notice.

■ Arch Size Chart

H	W	400	500	600	800	1000
		(16)	(20)	(24)	(31)	(39)
650 (25)						
850 (33)				STD		
1050 (41)						
1250 (49)						
1450 (57)						

Sizes in millimeters / (inches).

Modification rights reserved.

Pats., U.M. & design registered and/or pending.

© 1998 Strapack Corporation

DISTRIBUTED BY:



MillerBevco
UNIQUE PACKAGING SOLUTIONS

6209 Richards Dr. Shawnee, Kansas 66216

Tel: 800-821-2177 Fax: 913-322-1729

Email: Info@MillerBevco.com

www.MillerBevco.com

STRAPACK CORPORATION

1-2-17, Higashi Shinbashi, Minato-ku, Tokyo 105-0021, JAPAN

Phone 81-3-3289-1161 Fax. 81-3-3289-1160

(URL) <http://www.strapack.com>

(E-mail) info@strapack.com

STRAPACK INC.

30860 San Clemente St. Hayward, CA 94544 U.S.A.

Phone 1-510-475-6000 Fax. 1-510-475-6090